

KIT PRODUCT TECHNICAL DATASHEET

KIT AY/255

New 

Brushless 

Intensive use 

High Speed 

Digital Encoder 



Composition KIT AY/255

CODE	DESCRIPTION	QTY
AY/250/M (MASTER)	Electromechanical articulated motor HIGH SPEED BRUSHLESS, low voltage, super intensive use, with native encoder onboard, irreversible, ideal for swing gates with leaf up to 2.5 meters of length, with mechanical stopper in opening and closing. With digital controller, without articulated arms.	1
AY/250/S (SLAVE)	Electromechanical articulated motor HIGH SPEED BRUSHLESS, low voltage, super intensive use, with native encoder onboard, irreversible, ideal for swing gates with leaf up to 2.5 meters of length, with mechanical stopper in opening and closing. Without digital controller, without articulated arms.	1
LT336	Arms short for articulated AYRON series.	2
H93/RX20/I	Plug-in receiver 2 channels 433,92 Mhz (50 storable codes) for control unit series H70, B70, EDGE and CTRL.	1
SYNUS/2	Dual code transmitter (modality fixed code or rolling code), 433,92 Mhz. 2 channels, with radio for copy.	2
R90/F4ES	Pair of external photocells synchronized 24V AC/DC (max. 4 pairs).	1
FIFTHY/24	LED flashing light series FIFTHY 24V with integrated antenna.	1
R99/C/001	Signboard "Automatic Opening".	1

PRODUCT TECHNICAL SPECIFICATIONS

Power line supply	230V AC - 50Hz
Motor power supply	24V
Power rating	150W
Frequency of use	Intensive use

Torque	50 - 200 N m
Operating temperature	-20+55° C
Protection level	IP43
Reductor Type	Irreversible
Manoeuvre speed	4 - 1,5 Rpm
Opening time	10-18 s
Limit switch	Mechanical stopper in opening and closing
Onboard control unit	B70/2ML (AY/250/M)
Encoder	Digital native encoder SENSORLESS 48 PPR
Release system	Internal lever or external lever with cord (optional)
Batteries recovery	2 internal batteries 12V DC 1.2 Amp/h (inside AY/250/S)
Operating cycles per day (opening/closing - 24 hours no stop)	800
Maximum dimension product in mm (L x W x H)	245 x 189 x 270+60
Product weight packed (Kg)	28,7
Number items per pallet	16

PRODUCT DIMENSIONS AND PREPARING FOR INSTALLATION

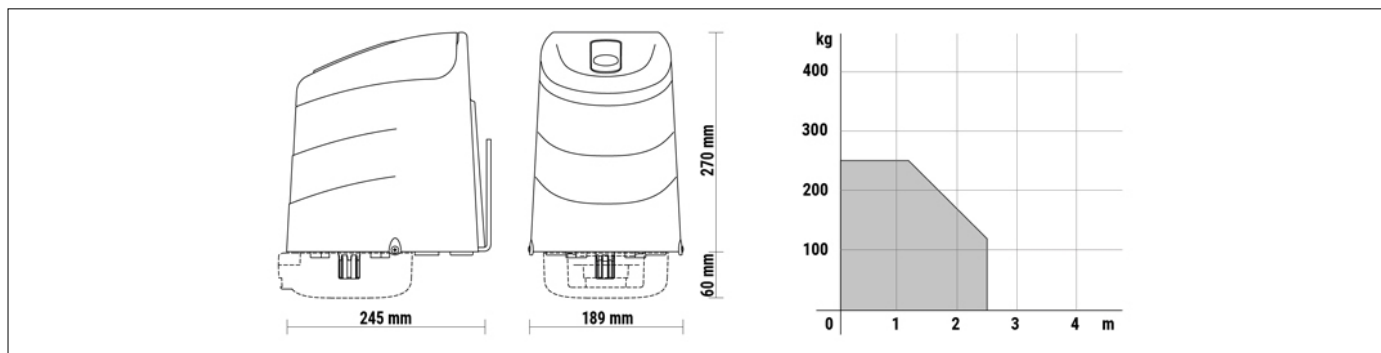

DIMENSIONS

PRODUCT PREPARING FOR INSTALLATION

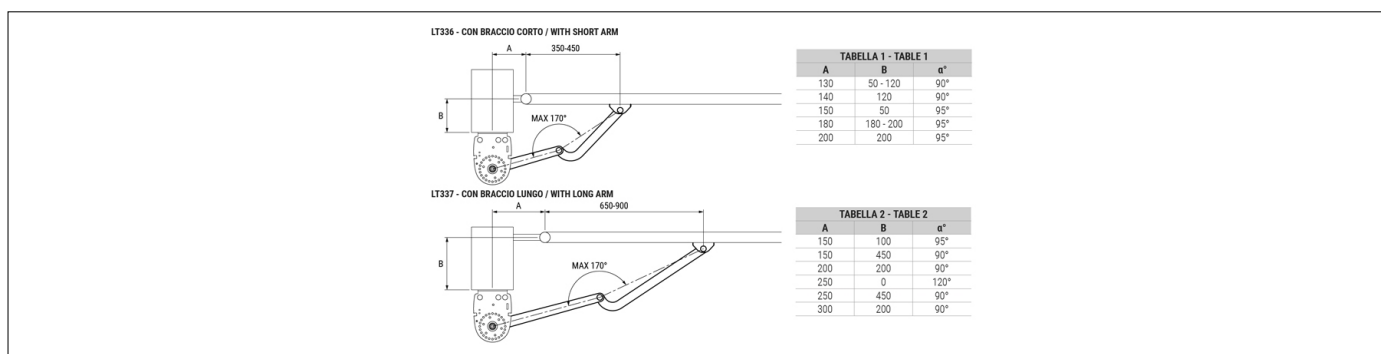

PREDISPOSITION FOR STANDARD INSTALLATION

PRODUCT ACCESSORIES

B71/BC Batteries charger for Brushless digital controller B70/1DC.	BT12V12 Battery 12V 1.2 Ah (1 pc).	B71/PBX24/BOX Battery chargers with solar panels for powering Brushless digital controllers at 24V DC in network mode.	B71/PBX24/BOX/115 Battery chargers with solar panels for powering Brushless digital controllers at 24V DC in network mode.	B71/PBX/BOX Battery chargers with solar panels for powering Brushless digital controllers in FULL SOLAR mode.	LT337 Arms long for articulated AYRON series.
KT249 Column mounting plate for AYRON series.	KT218 Gate pull bracket for series articulated.	RL673 External manual release kit without handle AYRON series.			