

# KIT PRODUCT TECHNICAL DATASHEET

# KIT MONOS4/220



## Composition KIT MONOS4/220

CODE	DESCRIPTION	QTY
<b>MONOS4/220</b>	Electromechanical actuator with telescopic arm, 230V AC, irreversible, ideal for swing gates with leaf up to 4 m length.	2
<b>H70/200AC/BOX</b>	Control unit for 2 motors 230V AC with slow down, with plastic box.	1
<b>H93/RX20/I</b>	Plug-in receiver fixed code 2 channels 433,92 Mhz (50 storable codes) for control unit series H70, B70, EDGE and CTRL.	1
<b>T80/TX2</b>	Dual code transmitter (modality fixed code or rolling code), 433,92 Mhz. 2 channels, with radio for copy.	2
<b>R90/F2ES</b>	Pair of external photocells synchronized.	1
<b>FIFTHY/230</b>	LED flashing light series FIFTHY 230V - 115V with integrated antenna.	1
<b>R99/C/001</b>	Signboard "Automatic Opening".	1

## PRODUCT TECHNICAL SPECIFICATIONS

Power line supply	230V AC - 50Hz
Motor power supply	230V AC
Power rating	200W
Frequency of use	30%
Thrust	2400N
Operating temperature	-20 C° +55 C°
Protection level	IP44
Reductor Type	Irreversible
Manoeuvre speed	1,66 cm/s
Opening time	24 s
Stroke	400 mm

Motor thermal protection	150° C
Limit switch	-
Encoder	-
Maximum dimension product in mm (L x W x H)	1223 x 178 x 111
Product weight packed (Kg)	19,4
Number items per pallet	21

# PRODUCT DIMENSIONS AND PREPARING FOR INSTALLATION

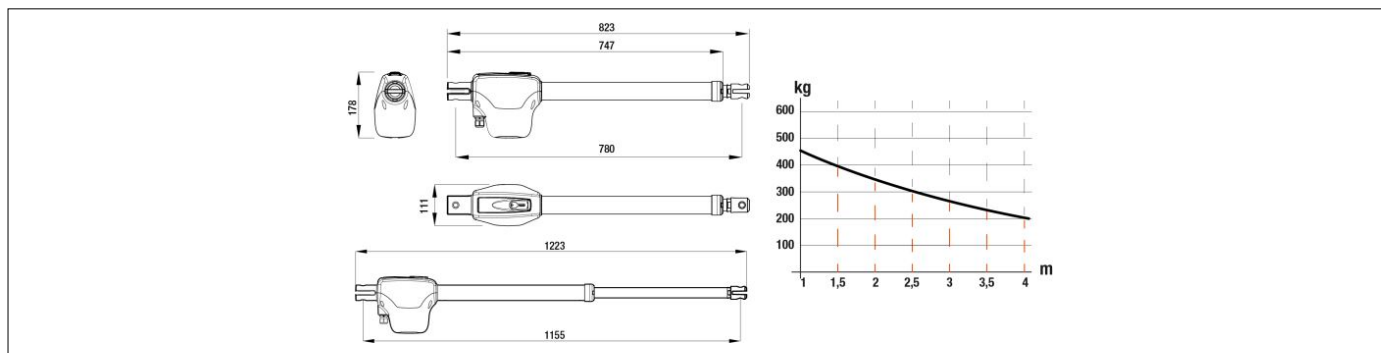

DIMENSIONS

# PRODUCT PREPARING FOR INSTALLATION

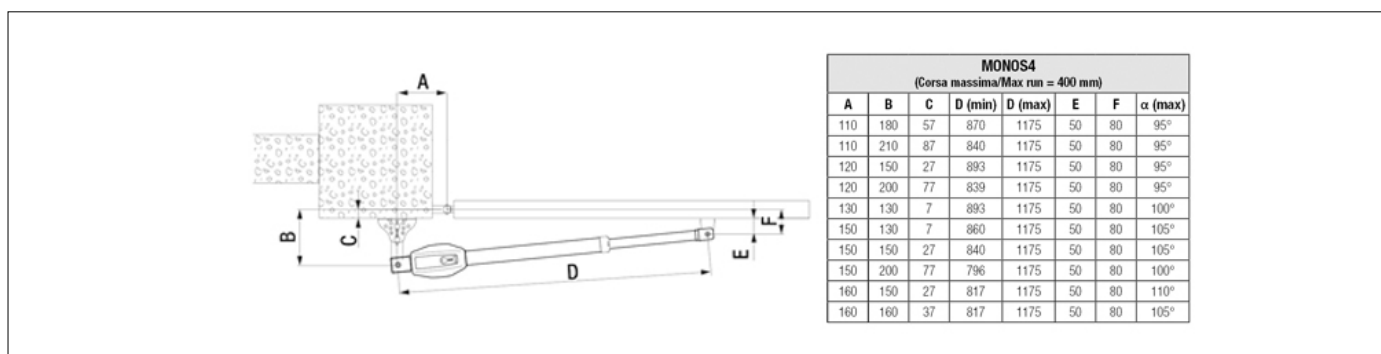

PREDISPOSITION FOR STANDARD INSTALLATION

# PRODUCT ACCESSORIES

